

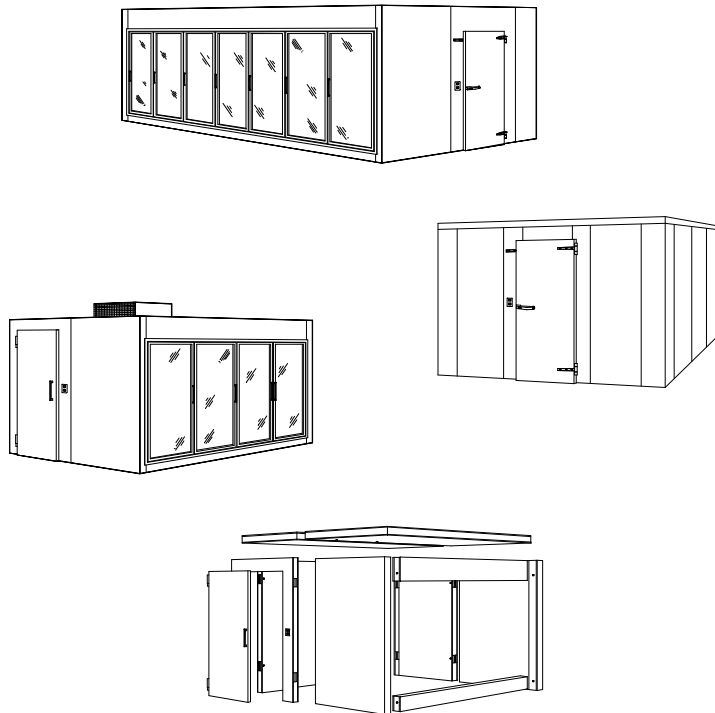

WALK-IN INSTALLATION INSTRUCTIONS



Tools Required

- Standard and Philips head screwdriver
- (2) Large Crescent wrenches
- Level
- Allen Wrench (Supplied by SRC)
- Drill motor and 1/4" masonry drill bit
(only required if anchoring panels directly to concrete floor)
- Caulking gun
- Tape measure
- Hammer
- Expanding Urethane Spray Foam Sealant

WEAR GLOVES DURING ASSEMBLY FOR HAND PROTECTION AND TO KEEP PANELS CLEAN

General Instructions

The following instructions include assembly for walk-in storage and display models:

- Refer to drawing supplied by SRC Refrigeration for panel layout
- All **Wall panels** are numbered near the top of panel. **Ceiling panels** are labeled "**C**".
If supplied...Floor panels are labeled "**F**"; *Header panels* (panel above glass doors) are labeled "**H**"
Sill panels (panels below glass doors) are labeled "**S**".
- **IMPORTANT:** All wall panels with "Decorative Finish" (except wood grain finishes) are shipped with a protective plastic coating to prevent unnecessary scratches during shipment and assembly. This protective coating must be peeled away from edges before wall panels are joined together. If this is not done it is nearly impossible to remove once the unit is in place. Finish removing plastic when job is completed.
- For floorless units, **DO NOT** install walk-in over carpeting, due to moisture and possible mildew problems.
- Panels are assembled by cam locks using allen wrench. (supplied by SRC see detail #1)

BEFORE BEGINNING INSTALLATION

Determine the highest part of the floor where your unit is to be positioned. This is where you should begin the panel assembly. You can determine the highest point by using a level to show your existing floors slope. By beginning at this point, you will be able to shim under the wall or floor panels as you proceed. These steps are necessary to keep your walk-in level & square. When placing walk-in adjacent to building wall(s) allow **2" minimum** clearance on all sides to allow for circulation and to prevent possible condensation on the exterior surface of the walk-in.

If screed was ordered with your cooler, this should be laid out first. Measure the pieces to fit the drawing, cut to size. The panels will slide into the channel - proceed with installation.

STEP 1 (Optional insulated floor)

If optional insulated floor is supplied by SRC Refrigeration, continue with this step (if not supplied, go immediately to Step 2). Starting at the highest point of your building, begin by joining all floor panels together in order as shown on drawing. **"BE SURE WALK-IN FLOOR IS LEVEL BEFORE PROCEEDING. SHIM APPROPRIATE AREAS UNTIL FLOOR IS LEVEL AND STABLE."**

NOTE: Use one "L" bracket at each panel seam.

STEP 2 (Standard floorless units)

Refer to panel print and begin assembly of walls (see detail #1). It is best to begin with panels at the highest point of your existing floor. As wall panels are joined together, continue to shim (supplied by customer) where necessary. It is important for walk-in panels to remain level for proper alignment and sealing. Install door frame panel in proper location, refer to walk-in door sheet for further instructions.

Note: Use one (1) "L" bracket at each panel seam to secure floor to pad (see detail 4A & 4B)

STEP 3

Verify assembled walls are square to each other. You can verify by measuring diagonally across walk-in floor, see detail #2. Measurements should be equal in each direction. Make adjustments as required. **Hint:** To square unit, push on corner where larger dimension was indicated and recheck both dimensions after you have moved corner. Repeat as needed until dimensions are equal.

STEP 4

Before securing the ceiling, recheck exterior seams at the top and bottom of wall panels are even. If not even, unlock appropriate wall panel(s), adjust as required and lock. Now install ceiling panels. **Important,** keep each ceiling panel and direction of cams installed exactly as shown on print. Verify ceiling panels are positioned evenly on all sides. Secure using 1/4" x 6" hex head lag screw with 1/4" washer. Install through top of ceiling panel at pre-drilled holes. **6" Lag bolt will begin to tighten in last 1-2 inches.**

Note: Once the ceiling panels are lagged down it is recommended to silicone the inside seam where ceiling panel sits on the wall.

STEP 5 (Glass display doors if supplied with units) See the manufacturers glass door installation sheet

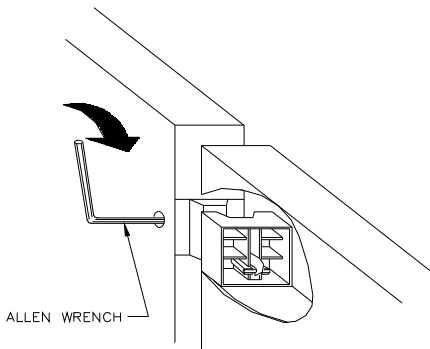

Detail #1

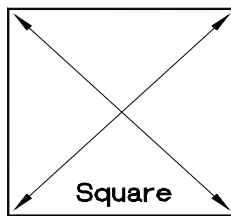

Detail #2

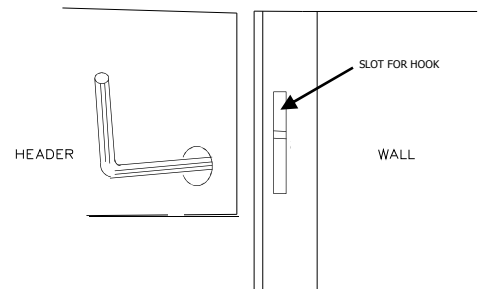

Detail #3

STEP 6

Walk-in door installation (see instructions affixed to face of door.)

STEP 7

Anchor wall panels to floor using metal angle bracket. Place (1) metal bracket on each side of door frame and space the remaining brackets evenly around box. (Position bracket over seam of two wall panels.)

For units with concrete floor - Detail #4A

Place metal angle bracket in position, mark hole and drill. Attach angle bracket using hammer nail into concrete and then secure to wall using #6 x 3/8" self starting screws.

For units with insulated floor panels - Detail #4B

Place metal angle bracket in position and secure to floor and wall with #6 x 3/8" self starting screws

Use silicone caulk provided to seal wall panels to building concrete floor. **Caulk all gaps especially at top and bottom of panel, using NSF approved caulk, where panel meets either insulated floor or existing concrete floor. (Note: For walk-in freezers, caulk all wall, ceiling, and floor joints running a bead of silicone on the male tongue of the panel.)** Seal any large gaps with spray foam (supplied by others). Proper ventilation is required when caulking. Follow instructions for proper handling of silicone caulk and/or spray foam, and allow curing.

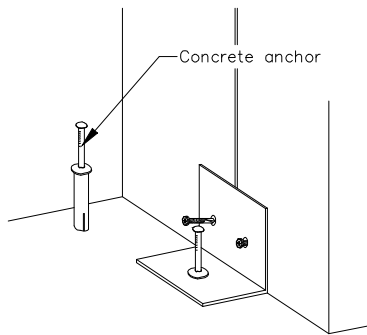

Typical Floor Bracket (concrete)

Detail #4A

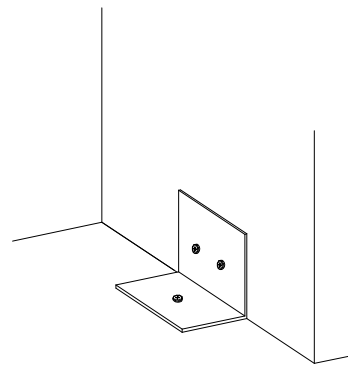

Typical Floor Bracket (insulated floor)

Detail #4B

STEP 8

For units supplied without insulated floor, customer is responsible for providing thin set cove based quarry tile or other NSF approved coving material.

STEP 9

Place all plastic buttons into cam lock holes. For those buttons that may be slightly loose, place a small amount of silicone caulk on inside rim of button and push into place.

STEP 10

Walk-in is now ready for refrigeration, electrical and plumbing connections by qualified contractors. Refer to electrical requirements provided by SRC Refrigeration.

STEP 11

Cleaning should be performed on a regularly scheduled basis. Wipe all interior surfaces with a solution of warm water and sanitizer.

INSTALLATION OF SERIES 9000 WALK-IN DOOR

CAUTION – HANDLE CAREFULLY

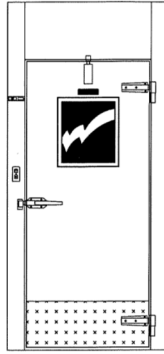

1. Remove bottom strap used during shipment to secure frame legs.
2. Damage will be less likely to occur by removing the door from the door panel before installation. (see note below and diagram #1)
3. Assemble walk-in following print provided. When box is assembled, the overall square of the cabinet should be checked. Diagonal measurements should be equal. The wall panels should be level and plumb. (see diagram #2)
4. Verify the door frame is plumb and level and the dimension near the top of the clear opening is identical to the opening at the bottom of the frame legs. This will ensure the door gasket seals properly to the metal contact plate (see diagram #3)
5. Place door back on hinges and close to recheck door is sealing properly on all sides. Adjust the door frame panel as needed. Secure the door frame panel by installing floor bracket on each side of opening (see diagram #4)
6. Adjust bottom wiper sweep. Sweep should make contact with floor in closed position (see diagram#5)
7. If a threshold is provided with your door, secure the threshold by using the pre-drilled holes. (Screws not provided)

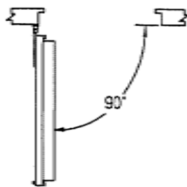

Diagram #1

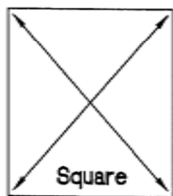

Diagram #2

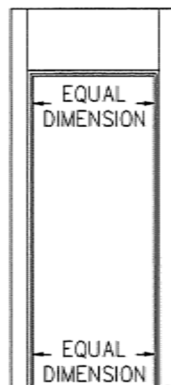

Diagram #3

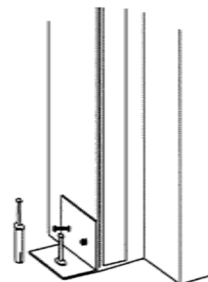

Diagram #4

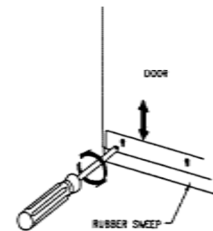
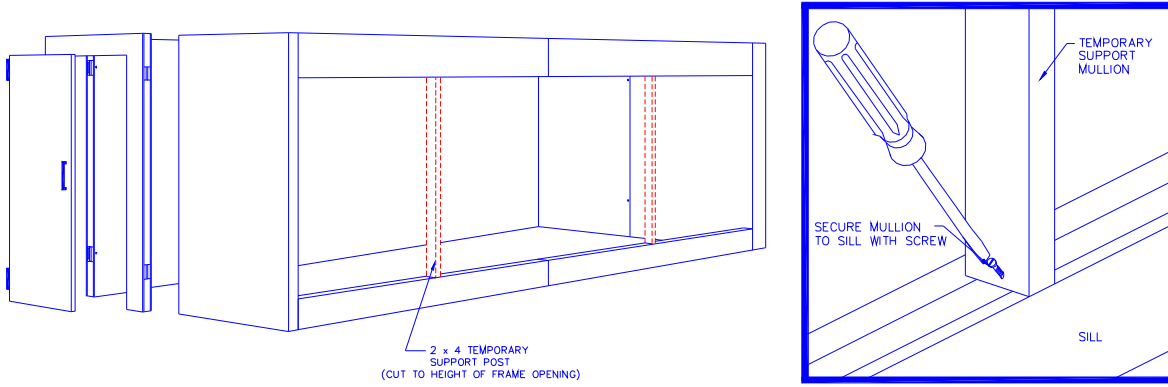

Diagram #5

To remove door from hinge, open door to at least 90°, lift up and remove off hinges. Note: upper hinge is the hinge used for the power spring conversion kit to be field installed. See additional instruction sheet for installation.

INSTALLATION OF MULTIPLE HEADER SECTIONS

For display door units consisting of 4 or more doors, it is necessary to temporarily support the header while erecting the cooler. All temporary support members are to be provided by the customer or installation technician. Cut support posts to match opening height shown on print. Temporary support mullions must be put in opening as shown on drawing below, evenly spacing one every header section. Secure with wood screws by screwing into wood support (See Drawing #1) on a 45 degree angle and screwing all the way through to the sill and header on other side. Leave wood support in place until such time as the door frames are installed into the door opening.



DRAWING #1

REFRIGERATION INSTALLATION

A licensed refrigeration serviceman is required to connect the compressor, coil, and refrigeration controls. For remote systems, serviceman needs to supply the required refrigeration tubing and refrigerant.

For units supplied with optional quick connect, self-contained refrigeration package, and tubing are factory supplied. All quick-connect systems are supplied with an EPA certified Nitrogen holding charge, and must be evacuated before refrigerant is added. Hang evaporator coil from ceiling in location shown on print. Place 5" long lag bolt with washer through top of ceiling panel and secure to coil from bracket with washer and nut. Place condensing unit on top of walk-in. Center condensing unit over line set protruding through center panel. Remove any caps covering ends of refrigeration lines. Connect lines together using wrench in each quick connect fitting (Note: DO NOT ALLOW REFRIGERATION LINES TO TWIST). All refrigeration penetrations through ceiling or walls must be sealed inside and out with silicone or expanding spray foam sealant.

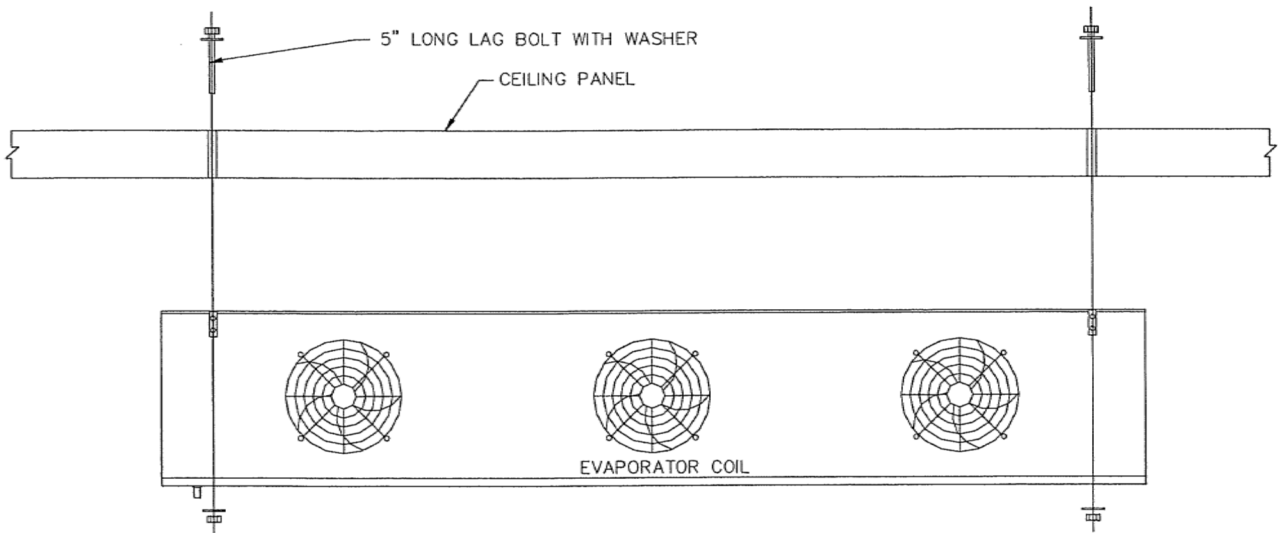

ELECTRICAL CONNECTIONS BY OTHERS

Walk-in is now ready to be wired by licensed electrician in accordance with local codes. Refer to electrical specifications supplied at time of order indicating connections required. Note: Interior evaporator cooling fans will operate continuously while compressor will cycle on/off as required. All electrical penetrations through ceiling or walls must be sealed inside and out with silicone or caulk. **Note: Leave power off until refrigeration serviceman has completed start-up.**

PLUMBING BY OTHERS

Condensate water from the evaporator will need to be drained to an internal bucket, utility sink, or floor drain, whichever is acceptable to local codes. Drain tubing to be supplied and connected by others. For refrigeration systems with water-cooled condensing units, all incoming water lines, shut-off valves and drain tubing to be supplied and connected by others.

TEST / CHECK / START-UP

After electrical connections have been completed, the system is ready for Test / Check /Start-up by a licensed refrigeration serviceman. A series of steps will be performed to ensure proper temperature will be maintained.

MAINTENANCE

Depending upon the condition of the air around condensing unit, periodical checks should be made to keep dust and lint clear from condensing unit. All units require fresh air for proper operation.

Condensate Drain Lines

Either copper or steel drain lines should be used and properly protected from freezing. In running drain lines, provide a minimum 1/4 inch per foot pitch for proper drainage. Drain lines should be at least as large as the evaporator drain connection. All plumbing connections should be made in accordance with local plumbing codes. All condensate drain lines must be trapped, and run to an open drain. They must never be located in a warm ambient. We recommend a trap on each evaporator drain line prior to any tee connections. Traps located outside, or extensive outside runs of drain line must be wrapped with a drain line heater. The heater should be connected so that it operates continuously. It is recommended that the drain line be insulated to prevent heat loss. A heat input of 20 watts per linear foot of drain line for 0°F (-18°C) room applications and 03 watts per linear feet for -20°F (-29°C) rooms is satisfactory. In freezers, the evaporator drain pan fitting should be included when heated and insulating the drain line.

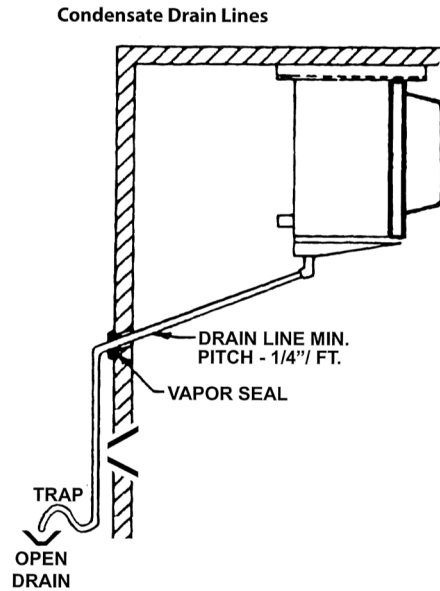

Inspect drain pan periodically to ensure free drainage of condensate. If drain pan contains standing water, check for proper installation. The drain pan should be cleaned regularly with warm soapy water.

WARNING: All power must be disconnected before cleaning. Drain pan also serves as cover of hazardous moving parts. Operation of unit with drain pan constitutes a hazard.

Traps on low temperature units must be outside of refrigerated enclosures. Traps subject to freezing temperatures must be wrapped with heat tape and insulated.

Note: Always trap single evaporator system drain lines individually to prevent humidity migration.

Phase Loss Monitor

The combination phase sequence and loss monitor relay protects the system against phase loss (single phasing), phase reversal (improper sequence) and low voltage (brownout). When phase sequence is correct and full line voltage is present on all three phases, the relay is energized as the normal condition indicator light glows. Note: If compressor fails to operate and the normal condition indicator light on the phase monitor does not glow, then the supplied electrical current is not in phase with the monitor. This problem is easily corrected by the following steps:

1. Turn power off at disconnect switch.
2. Swap any two of the three power input wires.
3. Turn power on. Indicator light should glow and compressor should start.
4. Observe motors for correct rotation.

Recommended Refrigerant Piping Practices

The system as supplied by **Heatcraft Refrigeration Products** was thoroughly cleaned and dehydrated at the factory. Foreign matter may enter the system by way of the evaporator to condensing unit piping. Therefore, care must be used during installation of the piping to prevent entrance of foreign matter. Install all refrigeration system components in accordance with applicable local and national codes and in conformance with good practice required for the proper operation of the system. The interconnecting pipe size is not necessarily the same size as the stub-out on the condensing unit or the evaporator.

The following procedures should be followed:

- (a) Do not leave dehydrated compressors or filter-driers on condensing units open to the atmosphere any longer than is absolutely necessary.
- (b) Use only refrigeration grade copper tubing, properly sealed against contamination.

- (c) Suction lines should slope 1/4" per 10 feet towards the compressor.
- (d) Suitable P-type oil traps should be located at the base of each suction riser of four (4) feet or more to enhance oil return to the compressor.
- (e) For desired method of superheat measurement, a pressure tap should be installed in each evaporator suction line in the proximity of the expansion valve bulb.
- (f) **When brazing refrigerant lines, an inert gas should be passed through the line at low pressure to prevent scaling and oxidation inside the tubing. Dry nitrogen is preferred.**
- (g) Use only a suitable silver solder alloy on suction and liquid lines.
- (h) Limit the soldering paste or flux to the minimum required to prevent contamination of the solder joint internally. Flux only the male portion of the connection, never the female. After brazing, remove excess flux.
- (i) If isolation valves are installed at the evaporator, full port ball valves should be used.

Refrigerant Pipe Support

1. Normally, any straight run of tubing must be supported in at least two locations near each end of the run. Long runs require additional supports. The refrigerant lines should be supported and fastened properly. As a guide, 3/8 to 7/8 should be supported every 5 feet; 1-1/8 and 1-3/8 every 7 feet; and 1-5/8 and 2-1/8 every 9 to 10 feet.
2. When changing directions in a run of tubing, no corner should be left unsupported. Supports should be placed a maximum of 2 feet in each direction from the corner.
3. Piping attached to a vibrating object (such as a compressor or compressor base) must be supported in such a manner that will not restrict the movement of the vibrating object. Rigid mounting will fatigue the copper tubing.
4. Do not use short radius ells. Short radius elbows have points of excessive stress concentration and are subject to breakage at these points.
5. Thoroughly inspect all piping after the equipment is in operation and add supports wherever line vibration is significantly greater than most of the other piping. Extra supports are relatively inexpensive as compared to refrigerant loss.

Example of Pipe Support

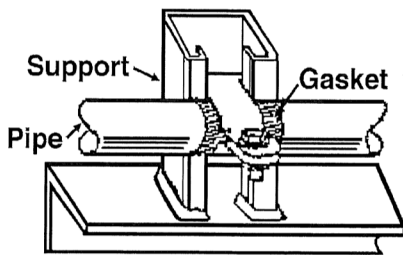

Condensing Unit / Compressor to Wall Support.

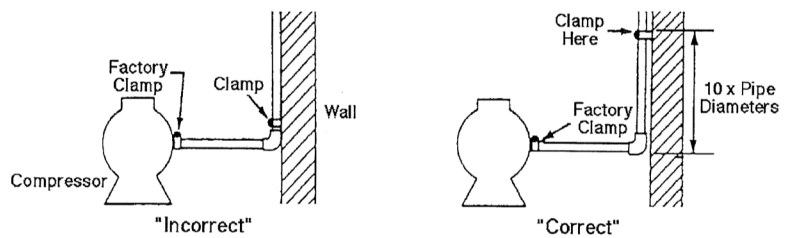

Suction Lines

Horizontal suction lines should slope away from the evaporator toward the compressor at the rate of 1/4 inch per 10 feet for good oil return. When multiple evaporators are connected in series using a common suction line, the branch suction lines must enter the top of the common suction line. For dual or multiple evaporator systems, the branch lines to each evaporator should be sized for the evaporator capacity. The main common line should be sized for the total system capacity. Suction lines that are outside of refrigerated space must be insulated.

Suction Line Risers

Prefabricated wrought copper traps are available, or a trap can be made by using two street ells and one regular ell. The suction trap must be the same size as the suction line. For long vertical risers, additional traps may be necessary. Generally, one trap is recommended for each length of pipe (approximately 20 feet) to ensure proper oil movement. See Figure 19 below for methods of constructing proper suction line P-traps.

NOTE: A suction line trap must be installed at the point where piping changes the direction of refrigerant flow from any horizontal run to an upward vertical run

Figure 19. Suction P-Traps.

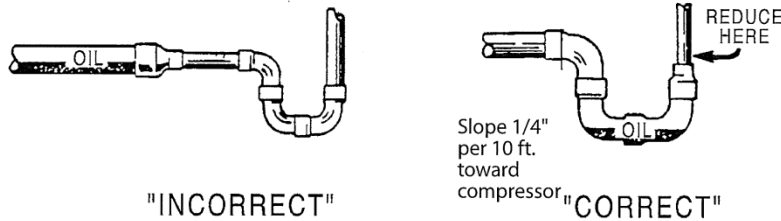
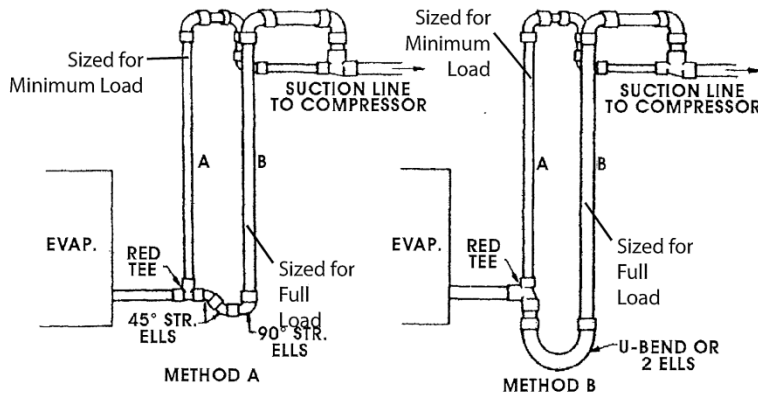

Figure 20. Double Suction Riser Construction



Liquid Lines

Liquid lines should be sized for a minimum pressure drop to prevent “flashing”. Flashing in the liquid lines would create additional pressure drop and poor expansion valve operation. If a system requires long liquid lines from the receiver to the evaporator or if the liquid has to rise vertically upward any distance, the losses should be calculated to determine whether or not a heat exchanger is required. The use of a suction to liquid heat exchanger may be used to sub cool the liquid to prevent flashing. This method of sub cooling will normally provide no more than 20°F sub cooling on high pressure systems. The amount of sub cooling will depend on the design and size of the heat exchanger and on the operating suction and discharge pressures. An additional benefit from the use of the suction to liquid type heat exchanger is that it can help raise the superheat in the suction line to prevent liquid return to the compressor via the suction line. Generally, heat exchangers are not recommended on R-22 low temperature systems. However, they have proved necessary on short, well insulated suction line runs to provide superheat at the compressor.

City & Tower Water Connections

In the refrigeration industry “City” and “Tower” are designations of temperature and flow conditions, not applications. The term “City” refers to operating conditions where incoming water is 75°F and condensing temperature is 105°F. “Tower” refers to a higher temperature relationship which is normally 85°F, incoming water and 105°F condensing temperature. Water circuits in some condenser models provide a center, or Tower, outlet connection to allow divided inlet water flow. This extra water port reduces water velocity, water pressure drop, and condenser wear in applications such as cooling towers where higher inlet temperatures and water flows occur.

Water Connections for City

For City water (open system) high pressure applications, the Tower connections are plugged.

Water Connections for Tower

For Tower usage and low pressure applications, both normal water connections will be used as inlets and the tower connection as an outlet.

Evacuation and Leak Detection

Due to the smaller molecule size of HFC's, they will tend to leak more readily than CFC's. Consequently, it is of the utmost importance that proper system evacuation and leak detection procedures be employed.

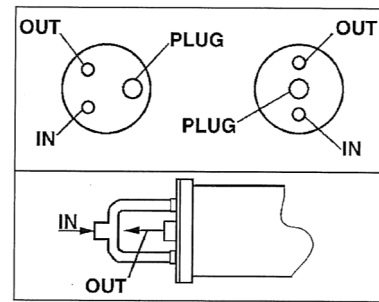

Copeland recommends a minimum evacuation to 500 microns. In addition, a vacuum decay test is strongly recommended to assure there is not a large pressure differential between the system and vacuum pump. Good evacuation processes include frequent vacuum pump oil changes and large diameter, short hose connections to both high and low sides of the system preferably using bronze braided hose.

Leak detection can be carried out in the conventional manner. If HCFC or CFC tracer gas is used, care must be taken to completely remove all traces of the gas prior to introducing HFC's.

Electronic leak detectors are now available that will sense HFC's. This is considered preferable since it removes the possibility of chlorine remaining in the system after leak testing with HCFC's and/or CFC's. There is a view that even small quantities of chlorine may act as a catalyst encouraging copper plating and/or corrosion and should therefore be avoided.

WARNING: HFC-134a has been shown to be combustible at pressure as low as 5.5 psig (at 350°F) when mixed with air at concentrations more than 60% air by volume. At lower temperature, higher pressures are required to support combustion. Therefore, air should never be mixed with HFC-134a for leak detection.

Within the last several years, manufacturers have developed fluorescent dye leak detection systems for use with refrigerants. These dyes mix with the lubricant and, when exposed to an ultraviolet light fluoresce, indicates the location of leaks. Copeland has tested and approved the Rigid "System Safe" dye and found it to be compatible with the compressor materials in systems.

Leak Testing

After all lines are connected, the entire system must be leak tested. The complete system should be pressurized to not more than 150 psig with refrigerant and dry nitrogen (or dry CO₂). The use of an electronic type leak detector is highly recommended because of its greater sensitivity to small leaks. As a further check it is recommended that this pressure be held for a minimum of 12 hours and then rechecked. For a satisfactory installation, the system must be leak tight.

Line Insulation

After the "nal" leak test, refrigerant lines exposed to high ambient conditions should be insulated to reduce heat pickup and prevent the formation of flash gas in the liquid lines. Suction lines must always be insulated with 3/4" wall Armstrong "Armflex" or equal. When required, liquid lines should be insulated with 1/2 inch wall insulation or better. The insulation located in outdoor environments should be protected from UV exposure to prevent deterioration of insulating value.

Evacuation

CAUTION: Do not use the refrigeration compressor to evacuate the system. Do not start the compressor while it is in a vacuum.

A good, deep vacuum pump should be connected to both the low and high side evacuation valves with copper tube or high vacuum hoses (1/4" ID minimum). If the compressor has service valves, they should remain closed. A deep vacuum gauge capable of registering pressure in microns should be attached to the system for pressure readings.

A shut off valve between the gauge connection and vacuum pump should be provided to allow the system pressure to be checked after evacuation. Do not turn off vacuum pump when connected to an evacuated system before closing shut off valve.

The vacuum pump should be operated until a pressure of 1,500 microns absolute pressure is reached — at which time the vacuum should be broken with the refrigerant to be used in the system through a drier until the system pressure rises above “0” psig.

NOTE: Refrigerant used during evacuation cannot be vented. Reclaim all used refrigerant. EPA regulations are constantly being updated to ensure your procedure follows correct regulations.

Repeat this operation a second time.

Open the compressor service valves and evacuate the entire system to 500 microns absolute pressure. Raise the pressure to 2 psig with the refrigerant and remove the vacuum pump.

Refrigerant Charging Instructions

1. Install a liquid line drier in the refrigerant supply line between the service gauge and the liquid service port of the receiver. This extra drier will ensure that all refrigerant supplied to the system is clean and dry.
2. When initially charging a system that is in a vacuum, liquid refrigerant can be added directly into the receiver tank.
3. Check equipment catalog for refrigerant capacity. System refrigerant capacity is 90% of receiver capacity. Do not add more refrigerant than the data tag indicates, unless the line run exceeds 25ft. Add additional refrigerant. Weigh the refrigerant drum before charging so an accurate record can be kept of the weight of refrigerant put in the system.
4. Start the system and finish charging until the sight glass indicates a full charge and the proper amount have been weighed in. If the refrigerant must be added to the system through the suction side of the compressor, charge in vapor form only. Liquid charging must be done in the high side only or with liquid metering devices to protect the compressor.

Low Head Pressure Systems

If you are charging the system by using a clear sight glass as an indication of proper charge the following must be considered. Check the condensing temperature. It must be above 105°F. If not, it will be necessary to reduce the amount of air going through the condenser from fans still running. Simply reduce the effective condenser face area to raise the discharge pressure above the equivalent 105°F condensing temperature and then proceed to charge to clear the sight glass. Adjust evaporator superheat at this time. Return to full condenser face area and allow the system to balance.

Field Wiring

WARNING: All wiring must be done in accordance with applicable codes and local ordinances.

The field wiring should enter the areas as provided on the unit. The wiring diagram for each unit is located on the inside of the electrical panel door. All field wiring should be done in a professional manner and in accordance with all governing codes. Before operating unit, double check all wiring connections, including the factory terminals. Factory connections can vibrate loose during shipment.

1. The serial data tag on the unit is marked with the electrical characteristic for wiring the unit.
2. Consult the wiring diagram in the unit cooler and in the condensing unit for proper connections.
3. Wire type should be of copper conductor only and of the proper size to handle the connected load.
4. The unit must be grounded.
5. For multiple evaporator systems, the defrost termination controls should be wired in series. Follow the wiring diagrams for multiple evaporator systems carefully. This will assure complete defrost of all evaporators in the system.
6. Multiple evaporator systems should operate off of one thermostat.
7. If a remote defrost timer is to be used, the timer should be located outside the refrigerated space.
8. For air cooled condensers, due to multiple low amp motors, we recommend using time delay fuse protection instead of circuit breakers.

Check Out and Start Up

After the installation has been completed, the following points should be covered before the system is placed in operation:

- (a) Check all electrical and refrigerant connections. Be sure they are all tight.
- (b) Observe compressor oil level before start-up. The oil level should be at or slightly above the 1/4 level of the sight glass.

- (c) Remove upper mounting nuts on the compressor feet. Remove the shipping spacers. Install the neoprene washers onto the compressor feet. Replace the upper mounting nuts and washers, allowing 1/16" space between the mounting nut and the neoprene spacer.
- (d) Check high and low pressure controls, pressure regulating valves, oil pressure safety controls, and all other safety controls, and adjust if necessary.
- (e) Check the room thermostat for normal operation and adjust.
- (f) Wiring diagrams, instruction bulletins, etc. attached to the condensing units should be read and filed for future reference.
- (g) All fan motors on air cooled condensers, evaporators, etc. should be checked for proper rotation. Fan motor mounts should be carefully checked for tightness and proper alignment.
- (h) Electric and hot gas evaporator fan motors should be temporarily wired for continuous operation until the room temperature has stabilized.
- (i) Observe system pressures during charging and initial operation. Do not add oil while the system is short of refrigerant unless oil level is dangerously low.
- (j) Continue charging until system has sufficient refrigerant for proper operation. Do not overcharge. Remember that bubbles in a sight glass may be caused by a restriction as well as a shortage of refrigerant.
- (k) Do not leave unit unattended until the system has reached normal operating conditions and the oil charge has been properly adjusted to maintain the oil level between 1/4 and bottom of the sight glass.
- (l) Make sure all Schrader valve caps are in place and tight.

CAUTION: Extreme care must be taken in starting compressors for the first time after system charging. At this time, all of the oil and most of the refrigerant might be in the compressor creating a condition which could cause compressor damage due to slugging. Activating the crankcase heater for 24 hours prior to start-up is required. If no crankcase heater is present, then directing a 500 watt heat lamp or other safe heat source on the lower shell of the compressor for approximately thirty minutes will be beneficial in eliminating this condition which might never reoccur.

WARNING: Scroll compressor is directional dependent. If noisy, change the phase of input wiring.

Operational Check Out

After the system has been charged and has operated for at least two hours at normal operating conditions without any indication of malfunction, it should be allowed to operate overnight on automatic controls. Then a thorough recheck of the entire system operation should be made as follows:

- (a) Check compressor discharge and suction pressures. If not within system design limits, determine why and take corrective action.
- (b) Check liquid line sight glass and expansion valve operation. If there are indications that more refrigerant is required, leak test all connections and system components and repair any leaks before adding refrigerant.
- (c) Observe oil level in compressor crankcase sight glass. Add oil as necessary to bring level to bottom 1/4 of the sight glass.
- (d) Thermostatic expansion valves must be checked for proper superheat settings. Feeler bulbs must be in positive contact with the suction line and should be insulated. Valves set at high superheat will lower refrigeration capacity. Low superheat promotes liquid slugging and compressor bearing washout.
- (e) Using suitable instruments carefully check line voltage and amperage at the compressor terminals. Voltage must be within 10% of that indicated on the condensing unit nameplate. If high or low voltage is indicated, notify the power company. If amperage draw is excessive, immediately determine the cause and take corrective action. On three phase motor compressors, check to see that a balanced load is drawn by each phase.
- (f) The maximum approved setting for high pressure controls on our air cooled condensing equipment is 425 psig. On air cooled systems, check as follows: Disconnect the fan motors or block the condenser inlet air. Watch high pressure gauge for cutout point. Recheck all safety and operating controls for proper operation and adjust if necessary.
- (g) Check defrost controls for initiation and termination settings, and length of defrost period. Set fail safe at length of defrost + 25%. Example: 20 minute defrost + 5 minutes = 25 minute fail safe
- (h) Check drain pan for proper drainage.
- (i) Check winter head pressure controls for pressure setting.
- (j) Check crankcase heater operation if used.
- (k) Install instruction card and control system diagram for use of building manager or owner.

System Balancing - Compressor Superheat

IMPORTANT: In order to obtain the maximum capacity from a system, and to ensure trouble-free operation, it is necessary to balance each and every system.

This is extremely important with any refrigeration system.
The critical value which must be checked is suction superheat.

Suction superheat should be checked **at the compressor** as follows:

1. Measure the suction pressure at the suction service valve of the compressor and determine the saturation temperature corresponding to this pressure from a "Temperature-Pressure" chart.
2. Measure the suction temperature of the suction line about one foot back from the compressor using an accurate thermometer.
3. Subtract the saturated temperature from the actual suction line temperature. The difference is superheat.

Too low a suction superheat can result in liquid being returned to the compressor. This will cause dilution of the oil and eventual failure of the bearings and rings or in the extreme case, valve failure.

Too high a suction superheat will result in excessive discharge temperatures which cause a breakdown of the oil and results in piston ring wear, piston and cylinder wall damage.

It should also be remembered that the system capacity decreases as the suction superheat increases. For maximum system capacity, suction superheat should be kept as low as is practical. Copeland mandates a **minimum** superheat of 20°F **at the compressor**. We recommend that the superheat **at the compressor** be between 20°F and 30°F.

If adjustments to the suction superheat need to be made, the expansion valve at the evaporator should be adjusted.

NOTE: All adjustable controls and valves must be field adjusted to meet desired operation. There are no factory preset controls or valve adjustments. This includes low pressure, high pressure, adjustable head pressure systems and expansion valves.

THANK YOU AGAIN FOR CHOOSING

